



UFZ

BUOY LEVEL GAUGE

UFZ 型浮标液位计

使用说明书

Operation Manual

UFZ - DT - JS - 1011 - 2018



Preface

Thank you for choosing the products of Dandong Top Electronics Instrument (Group) Co., Ltd.

This operation manual provides you with important information on installation, connection and commissioning as well as on maintenance, troubleshooting and storage. Please read it carefully before installation and commissioning and keep it as part of the product near the meter for easy reading.

This manual can be downloaded by entering the version number at www.ddtop.com .

If the instructions are not followed, the protection provided by the meter may be destroyed.

Trademark, Copyright and Restriction Instructions

Dandong Top Electronics Instrument (Group) Co.,Ltd.®, Dandong Top Pump Co., Ltd.®, DDTOP® are registered trademarks of the company.

The performance specifications of the meter are effective as of the date of publication and are subject to change without notice. Dandong Top Electronics Instrument (Group)Co.,Ltd. reserves the right to modify the products described in this manual at any time without prior notice.

Quality Assurance

Dandong Top Electronics Instrument (Group) Co.,Ltd. guarantees that all glass plate level gauge have no defects in materials and manufacturing processes within one year from the date of delivery.

During the warranty period, if the product returns with quality problems and the claim is determined by the manufacturer to be within the scope of warranty, Dandong Top Electronics Instrument (Group) Co.,Ltd. is responsible for repair or replacement of the buyer (or owner) free of charge.

Dandong Top Electronics Instrument (Group) Co.,Ltd. is not responsible for the costs caused by improper use of equipment, labor claims, direct or subsequent damage and installation and use of equipment. In addition to the special written warranty certificate for certain products of Dandong Top Electronics Instrument (Group) Co.,Ltd., Dandong Top Electronics Instrument (Group) Co.,Ltd. does not provide any express or implied warranty.

Quality

Dandong Top Electronics Instrument (Group) Co.,Ltd. has passed the ISO9001 quality system certification. The whole process of product production is strictly in accordance with the scope of the quality system, providing the strongest guarantee for product and service quality.

Contents

| | |
|---|---|
| 1. Safety Tips | 4 |
| 1.1 Explosion May Result In Death or Serious Injury. | 4 |
| 1.2 Process Leaks Can Cause Serious Injury or Death..... | 4 |
| 1.3 Failure to Follow Safe Installation Guidelines May Result In Death or Serious Injury..... | 4 |
| 2. Product Manual | 4 |
| 2.1 Main Structure of Product-Figure 1 | 4 |
| 2.2 Operating Principle | 5 |
| 2.3 Packing | 5 |
| 2.4 2.4 Transporting | 5 |
| 2.5 Warehousing | 5 |
| 3. Technical Characteristics..... | 5 |
| 3.1 Main Performance | 5 |
| 3.2 Main Performance | 5 |
| 4 Dimensional Schematic -Figure 2 | 6 |
| 5 Unpacking and Inspection | 6 |
| 5.1 Unpacking Inspection Notice | 6 |
| 5.2 Check Content | 6 |
| 6 Installation | 7 |
| 6.1 Installation Tool..... | 7 |
| 6.2 Installation Technical Requirements..... | 7 |
| 6.3 Installation Process-Figure 6 | 8 |
| 7. Fault Analysis and Elimination | 8 |
| 8 Disassembly | 9 |
| 8.1 Warning | 9 |
| 8.2 Waste Removal..... | 9 |
| 9 Product Certification | 9 |

1. Safety Tips

It is expressly prohibited to modify or change products for safety reasons, repair or replacement only allows the use of accessories specified by the manufacturer.

1.1 Explosion May Result In Death or Serious Injury.

When installing equipment in an explosive atmosphere, be sure to follow applicable local, national, international standards, codes, and procedures. Be sure to install the equipment in Intrinsically safe or non-flammable site operating procedures.

1.2 Process Leaks Can Cause Serious Injury or Death.

Care should be taken to lift the transmitter. If the process seal is damaged, the medium may leak at the joint.

1.3 Failure to Follow Safe Installation Guidelines May Result In Death or Serious Injury.

The operations described in this manual are performed by professionally trained and qualified professionals or end-user specialized professionals to complete.

2. Product Manual

2.1 Main Structure of Product-**Figure 1**

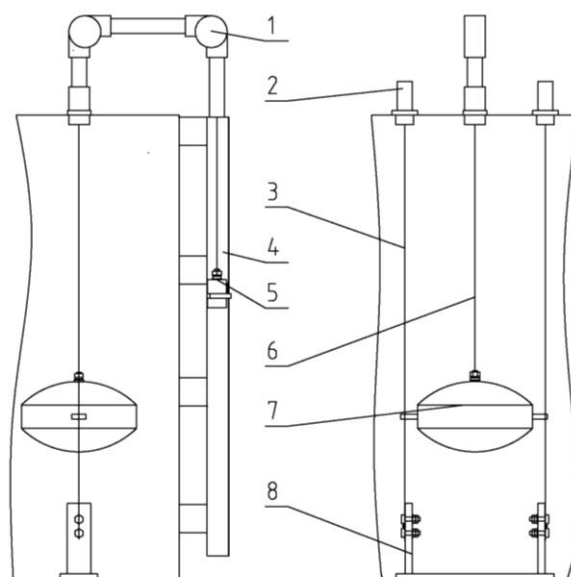

Figure 1 Main Product Structure

1. Transmission Mechanism
2. Tensioning Mechanism
3. Guide Wire Rope
4. Ruler
5. Heavy Hammer
6. Transmission Wire Rope
7. Buoy
8. Guiding Mechanism

2.2 Operating Principle

The UFZ-4A buoy level gauge is designed according to the principle of force balance. The working principle is shown in Figure 1. Let the weight of the float be W , the buoyancy of the float be F , the weight of the pointer weight be G , and the friction of the whole system be f . When the float is immersed in a position in the liquid, these forces are in equilibrium. $W-F-G\pm f=0$. When the level changes, it causes the change of the position of the float. The pointer hammer is moved by the wire rope, and the corresponding position of the level is displayed on the scale to achieve the purpose of level measurement.

2.3 Packing

Please send the packaging waste to a special recycling agency.

2.4 Transporting

When hoisting and transporting, please select qualified hoisting equipment and lifting straps, and pay attention to safety.

2.5 Warehousing

Storage Temperature $-20^{\circ}\text{C}\sim 40^{\circ}\text{C}$; Storage Humidity $\leq 40\%$.

3. Technical Characteristics

3.1 Main Performance

3.1.1 Product implementation standards: Q/AMM005-2010

3.2 Main Performance

3.2.1 Medium density: $\geq 0.6\text{g}/\text{cm}^3$

3.2.2 On-site indication accuracy: $\pm 20\text{mm}$

4 Dimensional Schematic -Figure 2

If the order is required to be a special size, the actual size will prevail.

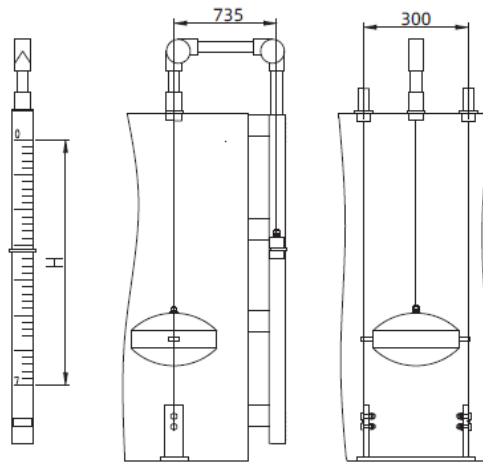

Figure 2 Dimensional Schematic

5 Unpacking and Inspection

5.1 Unpacking Inspection Notice

5.1.1 Check whether the product nameplate (Figure 3) is consistent with the supply list information.

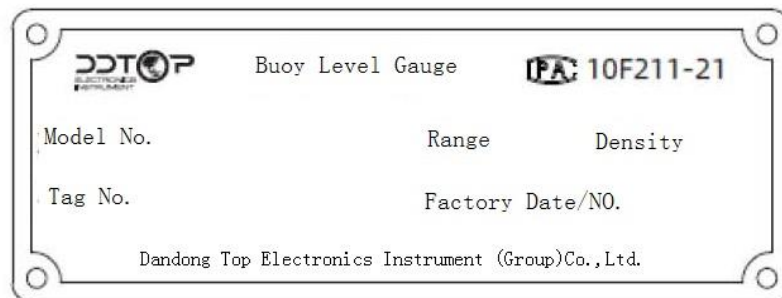

Figure3 Sample Nameplate

5.1.2 Check the quantity of each part against the packing list and the material is correct.

5.2 Check Content

5.2.1 Check the appearance of the instrument for defects, damage and other abnormal conditions.

6 Installation

6.1 Installation Tool

6.1.1 Wrench, flange gasket and flange bolts for process connections.

6.1.2 Level

6.2 Installation Technical Requirements

6.2.1 According to the position of the scale, the fixing bracket of the welding scale should be placed on a vertical line with a deviation of $\leq 2^\circ$ (Figure 4).

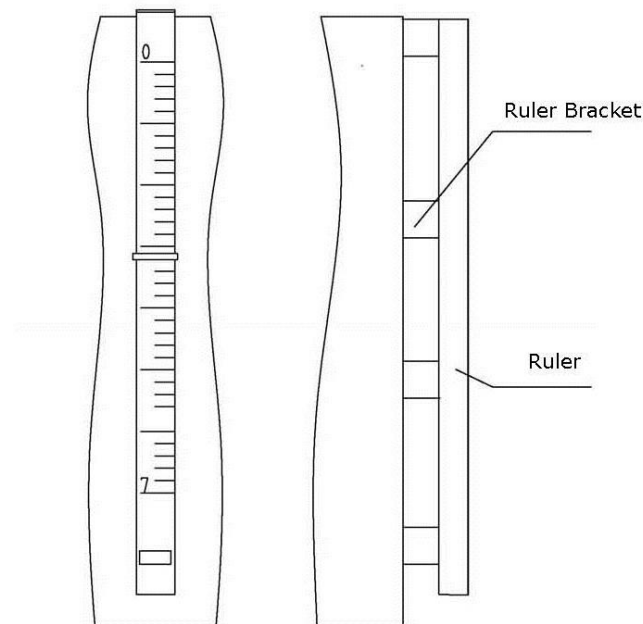

Figure 4 Installation

6.2.2 The bottom guiding mechanism and the buoy are taken into the tank from the inlet hole. By observing the perpendicularity of the guide wire at the top, it is determined that $\leq 2^\circ$, and the bottom guiding mechanism is welded and fixed to the bottom of the tank. (Figure 5)

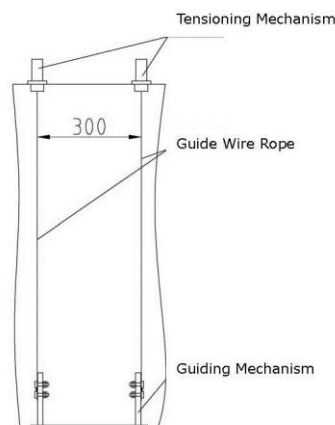

Figure 5 Installation

6.3 Installation Process-Figure 6

6.3.1 According to the site requirements of the tank, the observation direction of the scale, the opening position of the tank top, and the welding position of the bottom mechanism are determined.

6.3.2 The mounting bracket of the scale is welded according to the position of the scale.

6.3.3 Connect the overall display scale to the scale mounting bracket.

6.3.4 Take out the top transmission mechanism, and the tensioning mechanism determines the opening position of the tank top. After the error is correct, follow the installation diagram to open the tank (Figure 6).

6.3.5 Install the drive wire rope and the guide wire rope and pass it into the storage tank.

6.3.6 The bottom guiding mechanism and the buoy are taken into the tank from the inlet hole. By observing the perpendicularity of the guide wire at the top, it is determined that $\leq 2^\circ$, and the bottom guiding mechanism is welded and fixed to the bottom of the tank.

6.3.7 The guide wire is passed through the side hole of the float and fixed on the bottom guiding mechanism to ensure the tension and verticality of the wire rope.

6.3.8 One end of the transmission wire rope is connected with the float, the other end is connected to the weight by two pulleys, and the float is gently lifted in the tank, and the pointer on the heavy hammer outside the tank is simultaneously moved and slid freely.

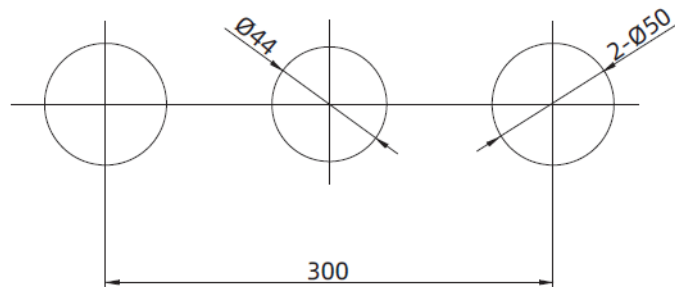

Figure 6 Installation procedure

7. Fault Analysis and Elimination

| Fault Phenomenon | Cause of Issue | Troubleshooting Method |
|--|--|--|
| The buoy moves up and down inflexibly. | <ol style="list-style-type: none"> Wire rope installation verticality is too large. The pulley is damaged. | <ol style="list-style-type: none"> Adjust the verticality of the wire rope installation. Replace the pulley. |

8 Disassembly

8.1 Warning

Attention should be paid to hazardous process conditions, such as pressure inside the vessel, high temperatures, corrosive or toxic media, etc.

8.2 Waste Removal

Waste disposal should be carried out in accordance with the current guidelines in each region.

9 Product Certification

| Product Certification | | |
|---|---|------------------------------------|
| Certification | | Certificate No. |
| | | Scope of certification/description |
| Formal approval certificate for measuring instruments |  | 10F211-21 |

C